



IMPORTANT SAFEGUARDS

When using an electrical appliance, basic precautions should always be followed, including the following:

READ ALL INSTRUCTIONS BEFORE USING THIS VACUUM CLEANER.

WARNING

To reduce the risk of fire, electric shock, or injury:

- Do not use outdoors or on wet surfaces.
- **Do not leave vacuum cleaner when plugged in.** Turn off the switch and unplug the electrical cord when not in use and before servicing.
- Do not allow to be used as a toy. Close attention is necessary when used by or near children.
- Use only as described in this manual. Use only manufacturer's recommended attachments.
- Do not use with damaged cord or plug. If vacuum cleaner is not working as it should, has been dropped, damaged, left outdoors, or dropped into water, return it to a service center before using.
- Do not pull or carry by cord, use cord as a handle, close a door on cord, or pull cord around sharp edges or corners. Do not run vacuum cleaner over cord. Keep cord away from heated surfaces.
- Do not use extension cords or outlets with inadequate current carrying capacity.
- Turn off all controls before unplugging.
- Do not unplug by pulling on cord. To unplug, grasp the plug, not the cord.
- Do not handle plug or vacuum cleaner with wet hands.
- Do not put any object into openings. Do not use with any opening blocked; keep free of dust, lint, hair, and anything that may reduce airflow.
- This vacuum cleaner creates suction and contains a revolving brush roll. Keep hair, loose clothing, fingers, and all parts of body away from openings and moving parts.
- Do not place cleaner on furniture or stairs as the brush roll may cause damage. Place cleaner on floor with the handle in storage position while using attachments.
- Do not pick up anything that is burning or smoking, such as cigarettes, matches, or hot ashes.
- Do not use without dust bag in place.
- Belt pulleys can become hot during normal use. To prevent burns, avoid touching the belt pulley when servicing the drive belt.
- Use extra care when cleaning on stairs.
- Do not use to pick up flammable or combustible liquids such as gasoline, or use in areas where they may be present.
- Store your cleaner indoors in a cool, dry area.
- Keep your work area well lighted.
- Unplug electrical appliances before vacuuming them.

SAVE THESE INSTRUCTIONS

CONSEILS DE SÉCURITÉ

Lors de l'utilisation d'un appareil électrique, quelques précautions élémentaires doivent être observées, incluant les suivantes:

LISEZ TOUTES LES INSTRUCTIONS AVANT D'UTILISER VOTRE ASPIRATEUR.

AVERTISSEMENT

Pour réduire le risque de feu, de choc électrique, ou de blessure:

- Ne pas utiliser à l'extérieur ou sur des surfaces mouillées.
- **Fermez le commutateur et débranchez l'appareil lorsque vous ne l'utilisez pas ou avant le nettoyage ou l'entretien.**
- Ne permettez pas qu'il soit utilisé comme jouet. Une attention particulière est nécessaire lorsque utilisé par ou près d'un enfant.
- Suivez les recommandations d'utilisation de ce manuel. Utilisez uniquement les accessoires recommandés par le fabricant.
- Ne pas utiliser si le cordon ou la fiche sont endommagés. Si l'aspirateur ne fonctionne pas comme il le devrait, s'il a été échappé, s'il est endommagé, s'il a été laissé à l'extérieur ou échappé dans l'eau, retournez-le à un centre de service avant d'utiliser.
- Ne pas le tirer ou le transporter par le cordon, ne pas utiliser le cordon en guise de poignée. Ne pas fermer une porte sur le cordon ou tirer le cordon sur des coins ou bordures pointus. Ne pas circuler sur le cordon avec l'aspirateur. Tenir le cordon à distance des surfaces chauffantes.
- Ne pas utiliser des rallonges ou des prises qui n'ont pas de capacité suffisante pour transporter le courant.
- Fermer tous les contrôles avant de débrancher.
- Ne pas débrancher en tirant sur le cordon. Pour débrancher, tenez la fiche et non le cordon.
- Ne pas manipuler la fiche ou l'aspirateur avec les mains mouillées.
- Ne pas rien insérer dans les ouvertures. Ne pas utiliser si des ouvertures sont bloquées; assurez-vous qu'elles soient dégagées de poussière, mousse, cheveux ou toute autre chose qui pourrait réduire le passage de l'air.
- Cet aspirateur crée de la succion et contient un rouleau-brosse tournant. Tenir les parties mobiles et les ouvertures loin des cheveux, du linge, des doigts et de toute partie du corps.
- Ne pas mettre l'aspirateur sur les meubles ou sur les escaliers car le rouleau-brosse peut faire des dommages. Placer l'aspirateur sur le plancher avec le manche en entreposage position temps que les accessoires sont en usage.
- Ne pas ramasser des objets qui brûlent ou fument comme les cigarettes, allumettes ou cendres chaudes.
- N'utilisez pas sans le sac de poussière en place.
- Les poulies du courroie peuvent devenir chaudes pendant l'utilisation normale. Pour prévenir des brûlures, évitez de touché la poulie du courroie lorsque vous réparez la courroie.
- Portez une attention particulière lorsque vous nettoyez les escaliers.
- Ne pas utiliser pour ramasser des liquides inflammables ou combustibles comme de l'essence: Ne pas utiliser dans les endroits où ces liquides pourraient être présents.
- Entrez votre aspirateur à l'intérieur dans un endroit propre et sec.
- Maintenez un bon éclairage à l'endroit où vous travaillez.
- Débrancher les appareils électrique avant de les balayer.

CONSERVEZ CES INSTRUCTIONS

To reduce the risk of electric shock, this appliance has a polarized plug (one blade wider than the other). This plug will fit in a polarized outlet only one way. If the plug does not fit fully in the outlet, reverse the plug. If it still does not fit, contact a qualified electrician to install the proper outlet. Do not change the plug in any way.

Afin de réduire le risque de choc électrique, cet appareil est muni d'une fiche polarisée (une des lames est plus large). Cette fiche ne peut être insérée dans une prise polarisée que d'une seule façon. Si la fiche ne peut être insérée dans la prise, retourner la fiche. Si la fiche ne peut toujours pas être insérée dans la prise, faire installer une prise adéquate par un électricien qualifié. Ne pas modifier la fiche.

GENERAL INFORMATION

The cleaner is designed to pick up dirt and dust particles. Avoid picking up hard or sharp objects with the cleaner to prevent bag tears and hose clogs with subsequent motor damage.

Service Information

The instructions in this booklet serve as a guide to routine maintenance. For additional service information telephone our toll free number for the nearest Eureka Authorized Warranty Station. **You should know the model, type and serial numbers when you call:**

USA: 1-800-282-2886
Mexico: 5670-6169
Canada: 1-800-282-2886

If you prefer, you can write to The Eureka Company, Service Division, 807 N. Main Street, Bloomington, Illinois 61701, USA. In Canada write to The Eureka Company, 866 Langs Drive, Cambridge, Ontario N3H 2N7. Refer to The Eureka Limited Warranty for complete service information.



DO NOT OIL the motor or the brush roll at any time. The bearings are permanently lubricated and sealed.

Thermal Cut Off

This vacuum cleaner has a special thermostat that protects the cleaner in case of motor overheating. If the cleaner suddenly shuts off, push the rocker switch to off (O) and unplug the cleaner. Check the cleaner for a possible source of overheating such as a full bag, a blocked hose or clogged filter. If these conditions are found, fix them and wait at least 30 minutes before attempting to use the cleaner. After the 30 minute period, plug the cleaner back in and turn on the switch. If the cleaner still does not run, then take it to a Eureka Authorized Service Center for repair.

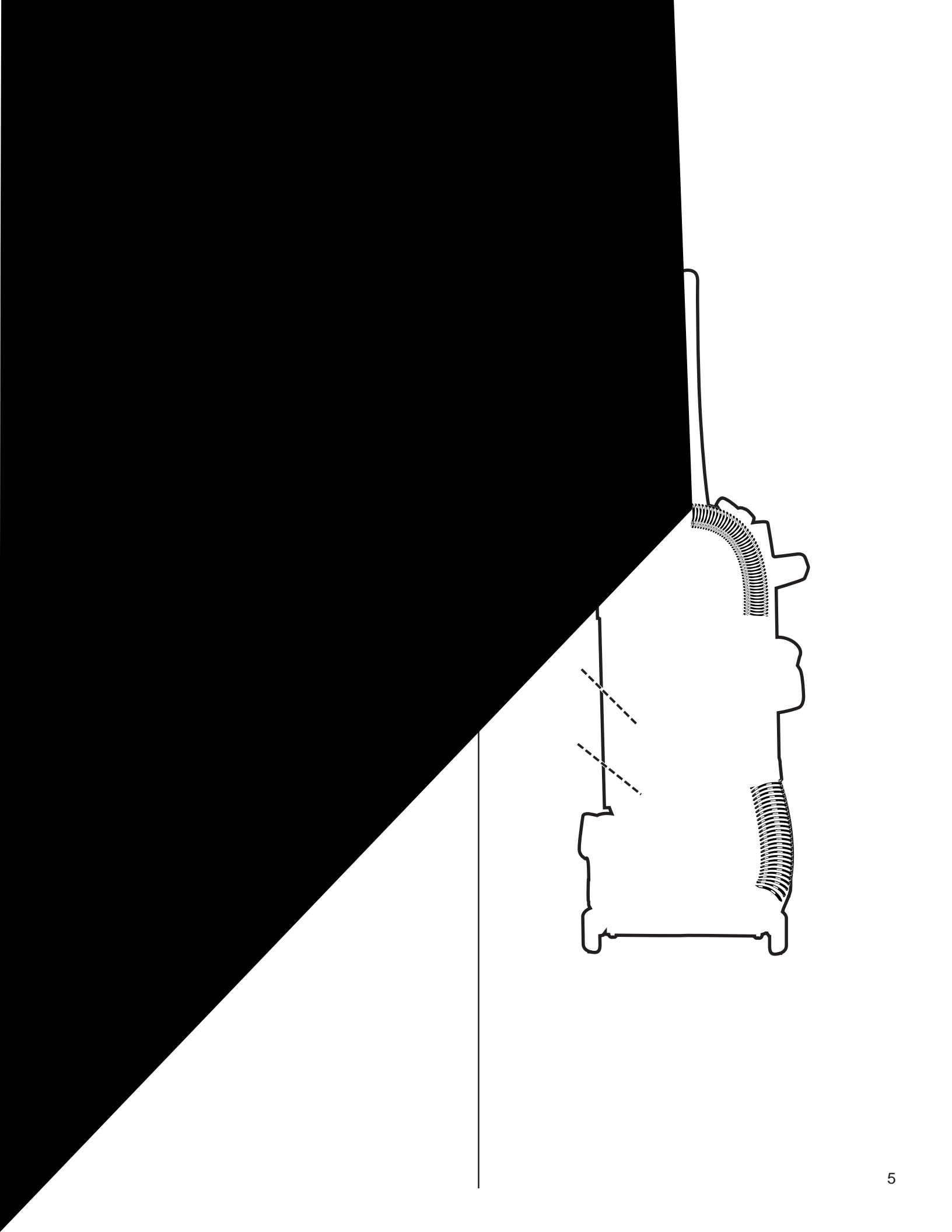

5. Remove front cover. Lift bag cover latch up and pull bag cover away from unit.

6. Check to be sure the paper bag collar is secure with the bag adapter inside the paper bag collar.

NOTE: Bag cover will not shut if paper bag is not properly installed.

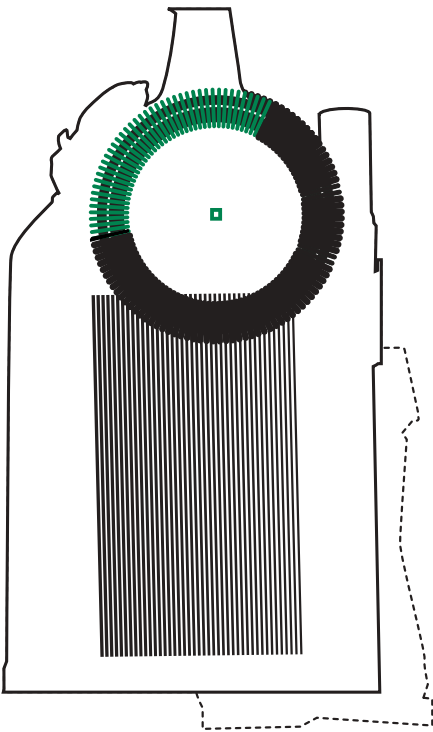

7. Replace front bag cover.

NOTE: See pages 13 & 14 for complete bag installation instructions.

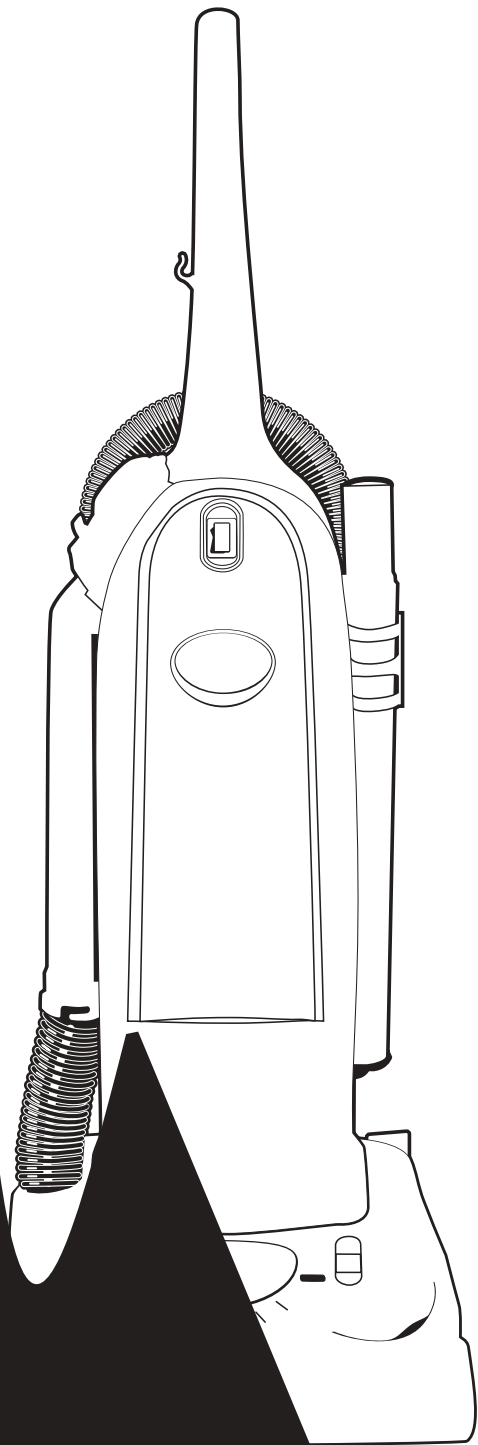

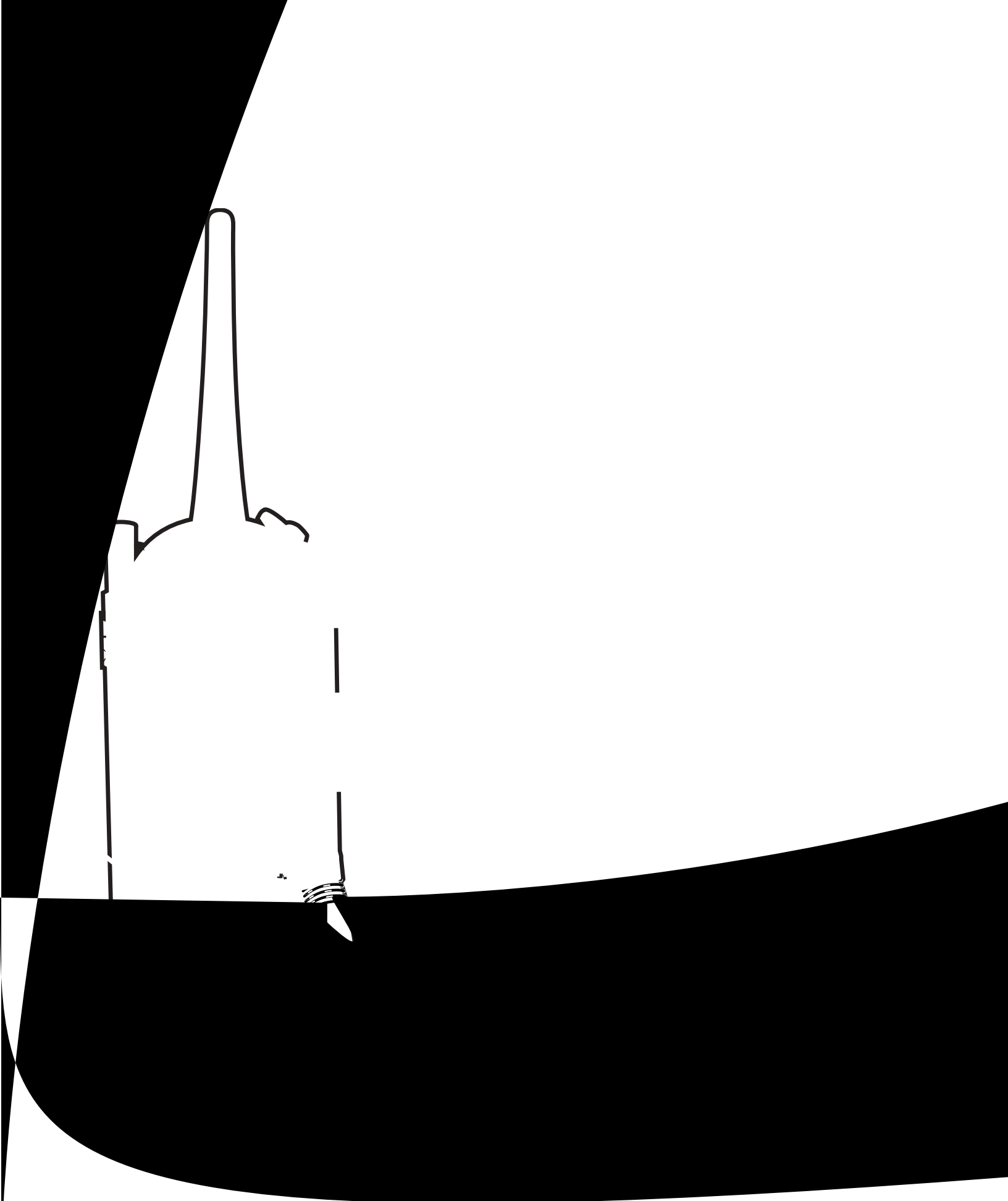

How To Use Accessories

NOTE: Place cleaner on floor with the handle in storage position while using accessories. Do not place cleaner on furniture or steps.

1. Remove hose from rear of cleaner.
2. Place desired accessory onto end of hose or wand.
3. Move hose/floor valve to hose position.

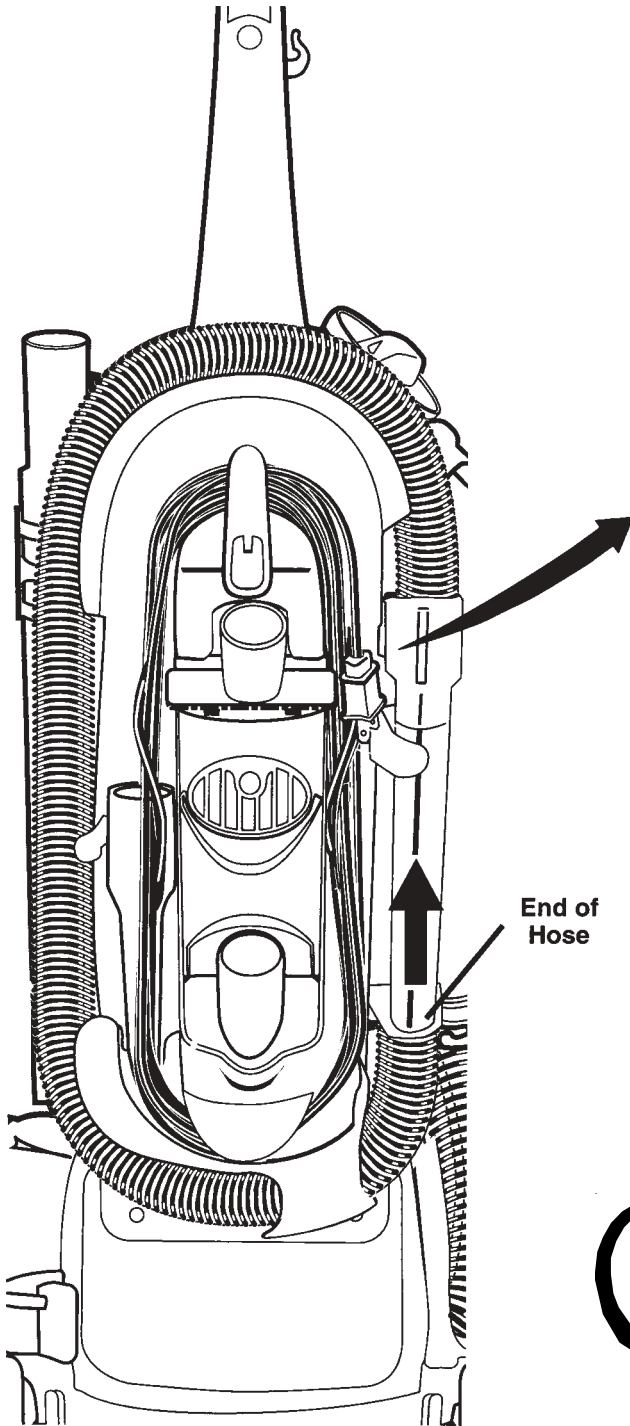

Dusting Brush is for furniture, blinds, books, lamp shades, shelves.

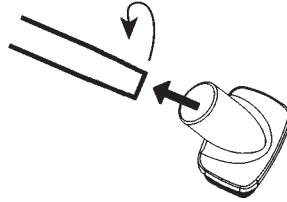

Dusting Brush

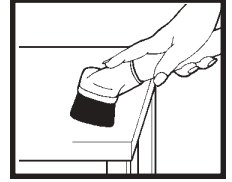

Upholstery nozzle is for curtains, draperies, cushions, fabrics.

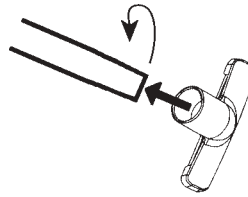

Upholstery Nozzle

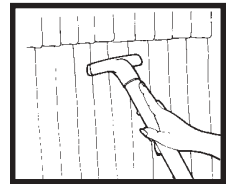

Crevice tool cleans corners, baseboards, between cushions.

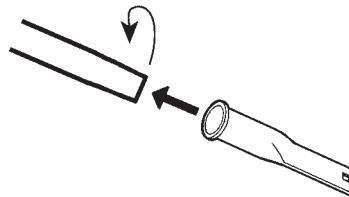

Crevice Tool

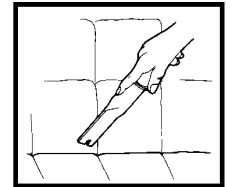

Extension wands

Nested extension wands to add reach.

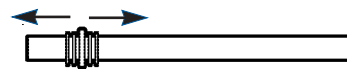

- Grasp both wands near ridges.

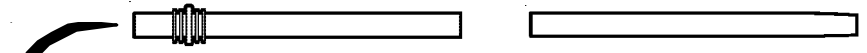

- Pull apart.

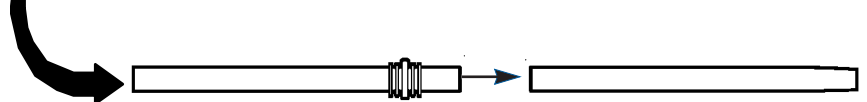

- Turn ridge end to center.
- Push wands together.

How to Remove and Check Clear Tubes

Low suction or poor pickup may be due to a blockage in the vacuum cleaner.

To Check Attachment Hose

1. Move hose/floor valve (A) to hose position.
2. Remove hose (B) and check suction at end of hose - if little or no suction, check disposable dust bag and filters. Change if needed. If no improvement proceed to step 3.

NOTE: Turn off the switch and unplug the electrical cord before checking tubes.

To Check Large base hose coming from hood, go directly to step 3.

3. Turn quarter turn fastener (C) to unlock.
4. Lift latch (D).
5. Pull small clear tube (E) down and away from cleaner.
6. At hose/clear tube connection, rotate twist lock (F) to release tube.
7. Check for blockages.
8. Remove large clear tube (G) by swinging back and pulling down and away from cleaner.
9. At large hose/clear tube connection, rotate twist lock (H) to release tube.
10. Check for blockages in both clear tubes (E/G) and both hoses (I).

NOTE: Clean tubes with mild detergent. Do not put them in a dishwasher. Make sure all parts are completely dry prior to reassembling.

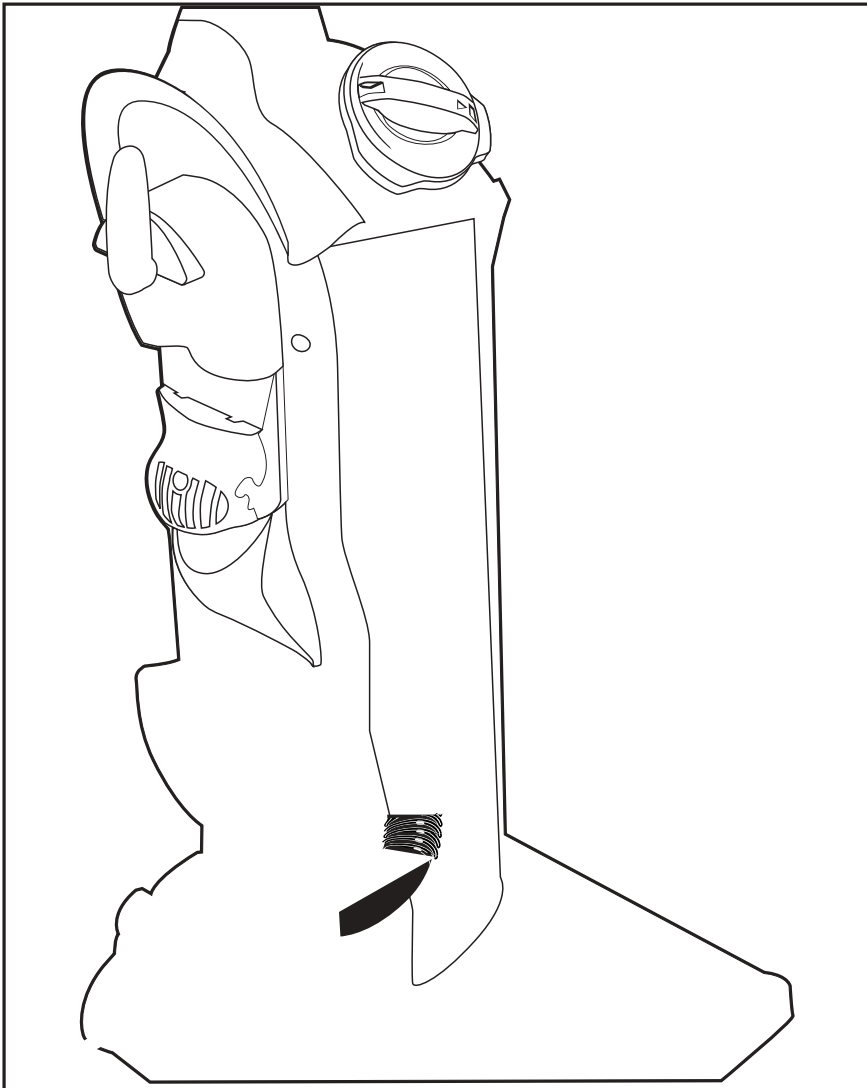

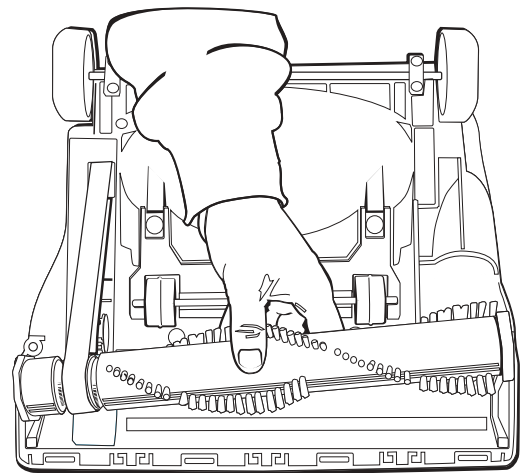
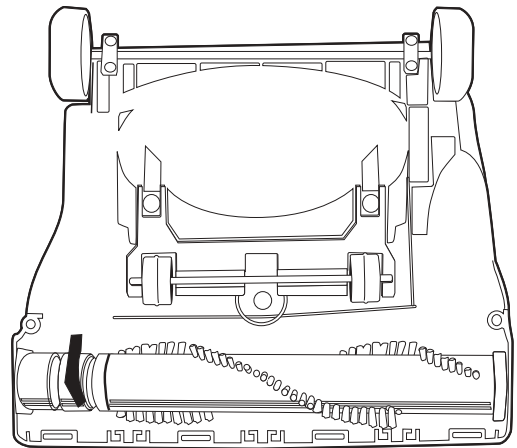
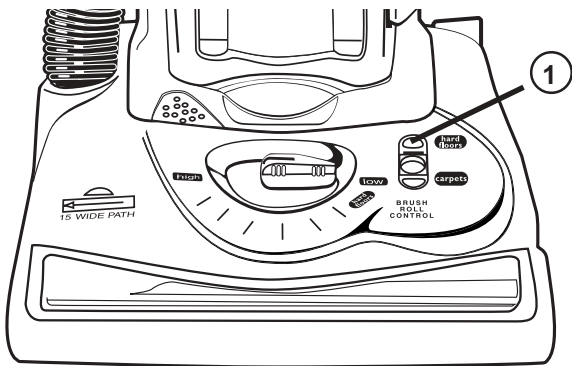

HOW TO MAINTAIN (continued)

The instructions in this booklet serve as a guide to routine maintenance. To avoid unnecessary service calls, check the bag, belt, and brush roll often.

How To Replace Brush Roll Belt (continued)

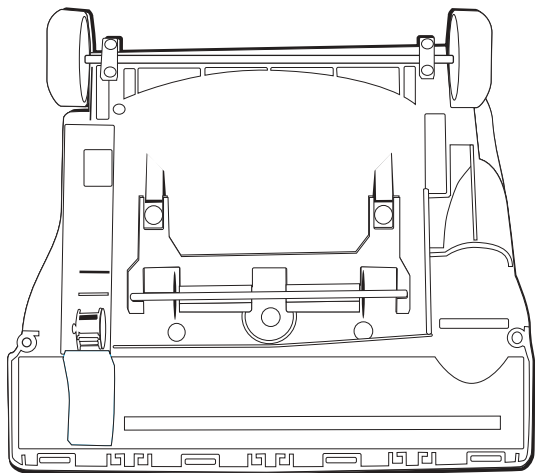

5. Insert right end into base. Make sure it is fully into position. Ensure belt is centered. **NOTE: The new belt will appear to be too large. This is normal.**

Check the motor filter with each disposable dust bag change. Clean or replace as needed. **Never operate without motor filter in place.**

1. Remove motor filter retainer and filter from inside bag compartment.
2. Install new filter, by placing on holding pegs. Replace filter retainer.

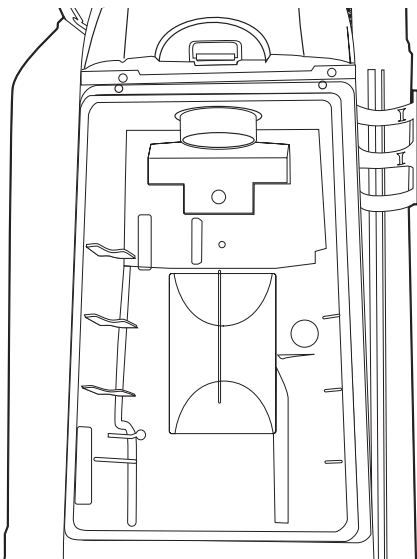

Cleaning And Replacing Filters (continued)

HEPA Filter

Check the HEPA filter with each disposable dust bag change. **Replace at least twice a year or after every six bag changes.**

To Remove HEPA Filter - Style HF2

1. Squeeze HEPA door latch and swing open.
2. Remove HEPA filter.

To Replace HEPA Filter

1. Place HEPA filter inside HEPA compartment with rubber seal against the back of the compartment.
2. Replace HEPA door. Push HEPA Door Latch against the unit until it locks into place.

Use replacement HEPA filter, 61111, Style HF2.

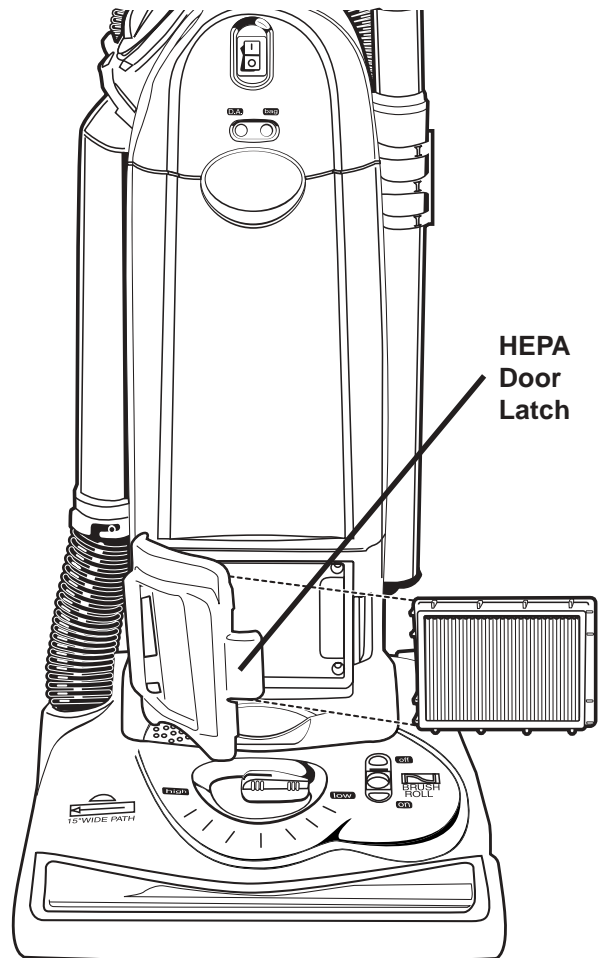

How To Change Light Bulb (only for models with a headlight)

NOTE: Turn off the power switch and disconnect the electrical cord before changing light bulb.

1. Lower handle to remove two screws from lens cover.
2. Pull lens cover from cleaner.
3. Pull up on light bulb to remove.
4. Push new light bulb into socket.
5. Replace lens cover.
6. Secure with two screws.

Use replacement bulb, 57940-2.

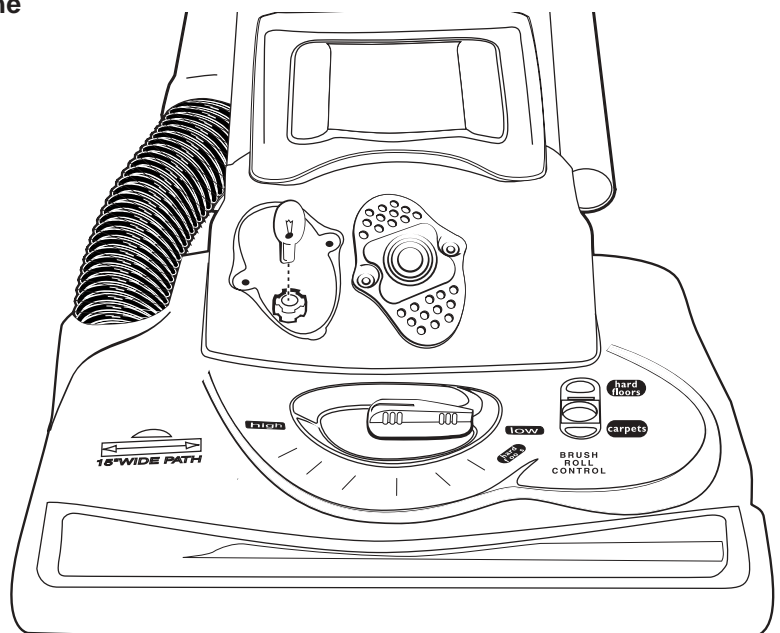

PROBLEM SOLVING - Call 1-800-438-7352 for replacement of broken or missing items.

NOTE: Turn off the switch and unplug the electrical cord before servicing.

PROBLEM	CAUSE	SOLUTION
Motor will not start.	<input checked="" type="checkbox"/> Electric Plug	<input type="checkbox"/> Push plug securely into outlet. <input type="checkbox"/> Try another outlet. <input type="checkbox"/> Check circuit breaker.
Motor suddenly stops.	<input checked="" type="checkbox"/> Thermal Cut Off	<input type="checkbox"/> Refer to page 8.
Does not clean the carpet or floor.	<input checked="" type="checkbox"/> Disposable Dust Bag and Filter(s) <input checked="" type="checkbox"/> Belt <input checked="" type="checkbox"/> Brush Roll <input checked="" type="checkbox"/> Hose <input checked="" type="checkbox"/> Brush Roll Control <input checked="" type="checkbox"/> Cleaner Height Setting	<input type="checkbox"/> Change the bag. Hint: If picking up fine dust, the bag may <u>not</u> look full, but a fine substance tends to reduce suction when it blocks the airflow through the paper bag and filter(s). Make sure the dust bag is installed properly. Make sure bag cover is installed properly. <input type="checkbox"/> Replace a cut, or out of shape belt. <input type="checkbox"/> Clean hair and thread from bristles and end cap area. Replace brush roll if bristles are worn. <input type="checkbox"/> Remove any clogs from the hose that restrict the airflow. <input type="checkbox"/> For carpet cleaning make sure brush roll control lever is in carpet position and the hose/floor selector is on floor selection. <input type="checkbox"/> For hard floor cleaning, make sure brush roll control is in hard floor position and hose/floor selector is on floor selection.
No suction at the end of the hose.	<input checked="" type="checkbox"/> Disposable Dust Bag and Filters <input checked="" type="checkbox"/> Hose <input checked="" type="checkbox"/> Hose/Floor Selector	<input type="checkbox"/> Change the bag. Hint: If picking up fine dust, the bag may <u>not</u> look full, but a fine substance tends to reduce suction when it blocks the airflow through the paper bag. <input type="checkbox"/> Check the filters and clean or replace if necessary. <input type="checkbox"/> Remove any clogs from the hose that restrict the airflow. <input type="checkbox"/> Check both ends of the hose. (See pages 10-11) <input type="checkbox"/> Remove any clogs from the clear tubes that restrict the airflow. Check hose/floor selector setting. <input type="checkbox"/> For above floor cleaning, make sure hose/floor selector is on hose.
Headlight not working.	<input checked="" type="checkbox"/> Light Bulb	<input type="checkbox"/> Replace light bulb.
Noise from the brush roll area.	<input checked="" type="checkbox"/> Brush Roll <input checked="" type="checkbox"/> Belt	<input type="checkbox"/> Remove base plate and clean debris from the brush roll area. <input type="checkbox"/> Replace a cut or out of shape belt.
Cleaner is hard to push.	<input checked="" type="checkbox"/> Cleaner Height Setting <input checked="" type="checkbox"/> Belt <input checked="" type="checkbox"/> Brush Roll On/Off	<input type="checkbox"/> Turn adjustment knob to a higher position. Hint: Put handle in operating position. Tilt the cleaner back to raise the front wheels off floor. Then turn the knob. <input type="checkbox"/> Replace a cut or out of shape belt. <input type="checkbox"/> Flip brush roll control lever to carpet position.
Brush roll will not turn.	<input checked="" type="checkbox"/> Belt <input checked="" type="checkbox"/> Brush Roll On/Off	<input type="checkbox"/> Replace cut or out of shape belt. <input type="checkbox"/> Flip brush roll control lever to carpet position. NOTE: Brush roll is not supposed to turn while the vacuum is in the upright position.
Dirt Alert red light will not go off.	<input checked="" type="checkbox"/> New carpet fibers.	<input type="checkbox"/> Over time loose new carpet fibers will diminish and will not trip the dirt alert sensors.
Dirt Alert red light will not come on.	<input checked="" type="checkbox"/> Dirt sensor is not working.	<input type="checkbox"/> Call 1-800-282-2886 8 a.m. to 7:30 p.m., (CST), Monday - Friday and 10 a.m. - 6:30 p.m. (CST) Saturday for the nearest authorized Eureka service center.
Cleaning height knob will not turn.	<input checked="" type="checkbox"/> Cleaner Height Setting	<input type="checkbox"/> Hint: Put handle in operating position. Tilt the cleaner back to raise the front wheels off floor. Then turn the knob.
Bag cover will not shut or close.	<input checked="" type="checkbox"/> No paper bag.	<input type="checkbox"/> A paper bag must be properly installed for the bag cover to close.

THE EUREKA LIMITED WARRANTY

What This Warranty Covers

Your Eureka cleaner is warranted to be free from all defects in material and workmanship in normal household use for a period of one year. The warranty is granted only to the original purchaser and members of his or her immediate household. The warranty is subject to the following provisions.

What This Warranty Does Not Cover

- Parts of the cleaner that require replacement under normal use, such as disposable dust bags, filters, drive belts, light bulbs, brush roll bristles, impellers and cleaning.
- Damages or malfunctions caused by negligence, abuse, or use not in accordance with the Owner's Guide.
- Defects or damages caused by unauthorized service or the use of other than Genuine Eureka parts.

What The Eureka Company Will Do

The Eureka Company will, at its option, repair or replace a defective cleaner or cleaner part that is covered by this warranty. As a matter of warranty policy, the Eureka Company will not refund the consumer's purchase price.

Warranty Registration

Please fill out and return the warranty registration card accompanying your cleaner.

Obtaining Warranty Service

To obtain warranty service you must return the defective cleaner or cleaner part along with proof of purchase to any Eureka Authorized Warranty Station. You will find the nearest location in the Yellow Pages, under "Vacuum Cleaners—Service and Repair." Be certain that the Warranty Station is "Eureka Authorized." For the location of the nearest Eureka Authorized Warranty Station or for service information, telephone toll free:

USA: 1-800-282-2886

Mexico: 5670-6169

Canada: 1-800-282-2886

If you prefer, you can write to The Eureka Company, Service Division, 807 N. Main Street, Bloomington, Illinois 61701, USA. In Canada write to The Eureka Company, 866 Langs Drive, Cambridge, Ontario N3H 2N7.

If it is necessary to ship the cleaner outside your community to obtain warranty repair, you must pay the shipping charges to the Eureka Authorized Warranty Station. Return shipping charges will be paid by the Warranty Station. When returning parts for repair, please include the model, type, and serial number from the data plate on the cleaner.

Further Limitations and Exclusions

Any warranty that may be implied in connection with your purchase or use of the cleaner, including any warranty of Merchantability or any warranty for Fitness For A Particular Purpose is limited to the duration of this warranty. Some states do not allow limitations on how long an implied warranty lasts, so the above limitations may not apply to you.

Your relief for the breach of this warranty is limited to the relief expressly provided above. In no event shall Eureka be liable for any consequential or incidental damages you may incur in connection with your purchase or use of the cleaner. Some states do not allow the exclusion or limitation of incidental or consequential damages, so the above limitation or exclusion may not apply to you.

This warranty gives you specific legal rights. You may also have other rights which vary by state.



Questions & Answers about Genuine Eureka Products

Q: Why should I use only Genuine Eureka paper bags, belts, and parts in my Eureka vacuum cleaner?

A: Using Genuine Eureka Products, which are made to our exacting specifications and engineered with emphasis on quality, performance, and customer satisfaction, ensures the long life and cleaning efficiency of your vacuum cleaner. Overall, this saves you money and helps to keep your home clean.

Q: How can I be sure I am using only genuine Eureka products in my vacuum cleaner?

A: Typically, packaged products and paper bags can be identified by a "Genuine Eureka Product" symbol (see illustration above). For further identification assistance, you may call our toll-free number, 1-800-282-2886, for the location of a nearby Eureka Authorized Warranty Station.

Q: Are there any differences between "made to fit" or "imitation" and Genuine Eureka paper bags, belts, and parts?

A: Yes, there are some very important differences in materials, quality, and reliability. Many customers have mistakenly purchased "imitation" paper bags and parts while thinking they purchased genuine. Unfortunately, many of these customers discovered the differences after they experienced related difficulties.

For Genuine Eureka Value, Accept No Imitations!

THE EUREKA COMPANY

Bloomington, Illinois 61701

Questions? Do Not Return To Store Call 1-800-282-2886

8 a.m. to 7:30 p.m., (CST), Monday - Friday and Saturday 10:00 a.m. - 6:30 p.m. (CST)

Accessory Items in This Carton

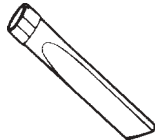

1 crevice tool

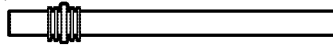

1 set of nesting wands

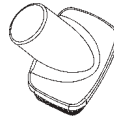

1 dusting brush

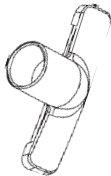

1 upholstery nozzle
(on some models)



1 hardware package
(3 screws)

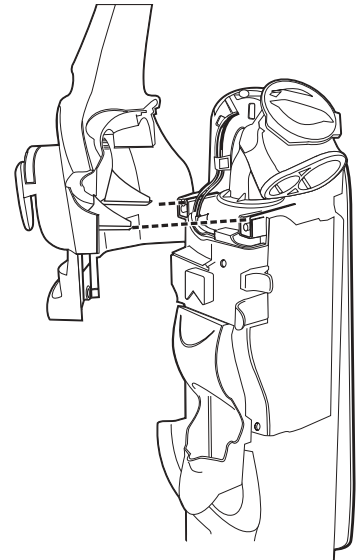

1 vacuum cleaner
handle to be installed
on unit

Thank you for selecting a Eureka cleaner.

**Don't Forget to Use
Genuine Eureka
Bags and Belts**

Caution: Damages caused by the use of non-genuine Eureka bags are not covered by the Eureka Limited Warranty.